

## C-8016LMA - Automatic Stapler w/ Long Mag

MANUAL/WARNING:

### IMPORTANT PLEASE READ BEFORE USING TOOL

Please read the following operating instructions manual. Refer to this manual for safety, adjustment and trouble shooting instructions. If you have any further questions please contact your distributor.





# TABLE OF CONTENTS

	PAGE
TOOL SPECIFICATION.....	3
SAFETY INSTRUCTIONS.....	4
COMPRESS AIR SYSTEMS.....	5
OPERATING INSTRUCTIONS.....	6
PRECAUTIONARY MEASURES.....	7
MAINTENANCE.....	8
TROUBLE SHOOTING.....	9
TROUBLE SHOOTING.....	10
EXPLODED VIEW OF TOOL.....	12
PARTS LIST.....	13



# TOOL SPECIFICATIONS

MODEL OF TOOL.....	C-8016LMA
DIMENSIONS (L x H x W) approx.....	14.84" x 1.73" x 6.3"
WEIGHT ( WITHOUT FASTENERS ) .....	2.98 lbs
RECOMMENDED OPERATING PRESSURE.....	70-120 PSI
NAIL SPECIFICATION.....	80 Series Fine Wire Stapler
NAIL CAPACITY.....	305 Staples

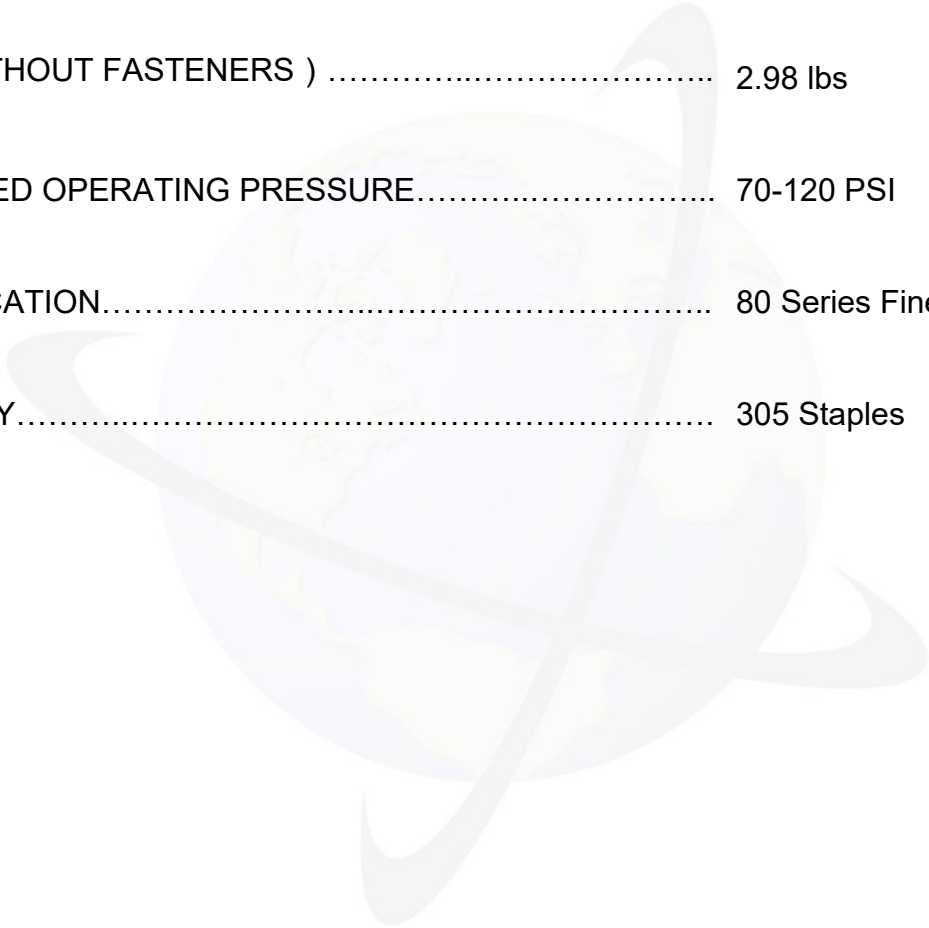



# SAFETY INSTRUCTIONS

**Use safety glasses:** all persons in the work area must always wear safety glasses in order to prevent eye injuries.

**Ear protection** must also be worn to prevent a possible hearing loss.

**Use clean dry regulated compressed air** at the recommended pressure (given in the technical data).

**Use only fasteners** according to manufactures technical data.

**Never** exceed the maximum recommended operating pressure of this tool.

**Never** use oxygen, carbon dioxide, combustible gases or any bottled gas as a power source.

**Always disconnect** the air supply when doing any tool maintenance, clearing a jam, moving location, leaving the work area or passing the tool.

**Regularly inspect** the safety, the trigger and the springs for free unhindered movement, never use a tool that requires servicing.

**Connect** the male free flow nipple to the tool side of the air line so that the tool is depressurized when disconnected from the hose.

**Never** load fasteners with the trigger safety depressed, it will result in a fastener being fired.

**Never** carry the tool with the safety depressed, if bumped it will result in a fastener being fired.

**Never** point the tool at yourself or at any one else.

**Never** fire a fastener into a hard brittle surface such as concrete, steel or tiles.

**Do not drive** fasteners too close to an edge or at too great an angle as the fastener may fly free or ricochet causing personal injury and damage.

**Always** ensure that the work area is amply lit so as to avoid possible accidents.

**Never** remove, tamper with or otherwise cause the tools operating controls to become inoperable.



## COMPRESSED AIR SYSTEM

Proper use of the fastener driving tool requires an adequate quantity of clean dry compressed air. All compressed air contains moisture and other contaminants detrimental to the tool and so it is recommended to use an in line lubricator as close to the tool as possible (within 15 feet (4.5m)). The lubricator should be well maintained so as to ensure optimum performance and power. All parts of the air supply system should be clean and contaminant free.

The tool shall only be connected to a compressed air line where the maximum allowable pressure cannot be exceeded by a factor of more than 10%, which can for example be achieved by a pressure reduction valve which includes a downstream safety valve.

A male free flow coupling should be connected to the tool side of the system with the female coupling providing a seal to prevent air loss from the compressor tank upon disconnection. Never connect a female disconnect coupling to the tool side as this provides a seal which prevents loss of compressed air from the air tank and if connected to the tool it could seal a charge of air in the tool which could lead to an unintentional actuation. Do not mount a swivel connector in the air supply line.

Different work pieces will require different operating pressures, the harder the wood the greater the pressure required. Remember always use the lowest pressure required for the work process at hand, this being to prevent unnecessarily high noise levels, increased wear and resulting failures.

***WARNING*** *Keep hands and body away from the discharge area of the tool when connecting the air supply and always disconnect the tool when servicing, adjusting, cleaning and when the tool is not in use.*



# OPERATING INSTRUCTIONS

## Loading fasteners

Press the latch mechanism and slide back the magazine unit.  
Load fasteners into the magazine.  
Close the magazine.

## Type of actuating and trigger system

**No Safety:** This model stapler is not equipped with a safety. When you pull the trigger a single staple, or series of staples will be fired. Always point the stapler towards your work piece.

## Operating procedures

**Protective equipment:** before using any tool always ensure that you and those in the work area are using the appropriate working equipment, including safety goggles.

**Firing a fastener:** to fire a fastener hold the nose of the tool against the work piece, then pull the trigger to fire a fastener. By pulling the trigger half-way a single shot is fired. Full trigger will activate the automatic firing setting, until released.

**Adjusting Speed:** use the dial on side of trigger to adjust how fast or slow the staples are fired.

Always use the lowest possible air pressure for the following reasons,

- save energy
- less noise will be produced
- a reduction in fastener driving tool wear will be achieved

Any defective or improperly functioning tool must be immediately disconnected from the compressed air supply and passed to a specialist for inspection.



## PRECAUTIONARY MEASURES

### *'Respect your tool and never horseplay'*

- Always assume that the tool contains fasteners.
- Remove finger from the trigger when not driving fasteners. Never carry the tool with your finger on the trigger, as the tool will fire a fastener if the trigger is bumped.
- Keep tool pointed in a safe direction at all times, never pointing it toward yourself or others whether it contains fasteners or not.
- Never attempt to drive a fastener into material that is too hard, or at too steep an angle or near the edge of the work piece, the fastener can ricochet causing personal injury. Remember, always hold nose right up to and firmly against the work material.
- Disconnect the tool from the air supply before performing any maintenance, leaving the work area, moving to another location, or handing the tool to another person.
- Always disconnect the tool before removing any jams.
- Carefully check the tool for proper operation of trigger mechanism. Do not use the tool unless the trigger and any other of the operating control are functional. Do not use the tool if the tool is leaking air or needs repair.
- Written approval of the tool manufacturer must be obtained before making any modifications to the tool.



## MAINTENANCE

### *'Clean and inspect your tool every time you use it'*

The employer and tool operator are responsible for assuring that the tool is kept in safe working order. Furthermore only service personnel trained by the manufacturer, distributor, or employer shall repair the tool.

**CAUTION** Always remove the air supply before commencing any cleaning or inspection.

Wipe tool clean and inspect tool for wear or damage. Use non-flammable cleaning solutions to wipe the tool. Never soak the tool in these solutions as they can cause internal damage.

Always ensure that all of the screws are kept tight as loose screws can cause injury or can damage the tool.

Tools requiring lubricant: If the tool is used without an in line lubricant then be sure to put in about 3 drops of lubricant at the start of each workday and 3 drops for every 1,000 fasteners fired there after.

Tools shall be repaired or equipped only with parts or accessories that are supplied or recommended by the tool manufacturer / supplier.

**NEVER** use a tool that requires repair work.





# TROUBLE SHOOTING

Failure	Possible causes	Check Method	Counter measures
No staple is ejected	Incorrect staples are loaded. Abnormal staples are loaded (large-sized head ,bent, etc.)	Check if recommended staples are loaded	Use recommended staples Remove abnormal staples and load normal staples
	Magazine Unit Push lever Defective feeder (either bent or broken) Defective feed spring (worn or broken)	Check for abnormalities of staple feeding portion (deflected, worn, deformed broken)	Repair deformed parts Replace defective parts
	Narrow or wide width of the Magazine groove Worn staple supporting portion of Magazine Abnormal staple guide groove of Blade Guide (deflected, deformed or broken)	Load staples and confirm that they will move smoothly	
No staple is ejected	Adhesive fragment or wood dust sticking on the Magazine or staple feeder		Remove adhesive fragment or wood dust
	Push lever	Check push lever movement	Replace
	[Output unit :Piston or driver] Air pressure too low	Carry out idle driving and check the return of the driver blade	Check compressor
	Worn piston ring		Replace piston ring
	Defective piston bumper		Replace the piston bumper
	Defective bumper piece (defective, worn or broken)		Replace the piece
	Defective O-ring (disconnected, deformed or broken)		Reassamble or replace the o-ring
	Defective driver blade, (deflected, deformed or broken)		Replace
Defect inside cylinder (adhesive or wood fragment, worn)	Check if the nailer drives at minimum operating pressure	Remove adhesive fragment or wood dust	



## TROUBLE SHOOTING

Failure	Possible causes	Check Method	Counter measures
The driven staple is bent	Staples are inaccurately fed into the Blade Guide Incorrect staples are loaded	Refer to item above	Refer to item above
	Worn driver blade	Check if the driver blade is extremely worn or not	Replace the driver blade
	The wood is too hard	Check if the nails bend on softer wood or not	Stop using the tool
The driven staples do not fully penetrate the work piece (heads protrude)	The wood is too hard	-	Stop using the tool
	Air pressure too low	-	Adjust the air pressure
	Worn or broken driver blade	Carry out idle driving and check if the driver blade protrudes from the blade guide nose	If the driver blade does not protrude from the blade guide replace
	Incorrect driving depth adjustment	Check if the tip of the driver blade is excessively worn or not	Adjust the guide plate to the appropriate position.
	Defective piston ring (worn or broken) Defective inner surface of cylinder (worn or rough)	Disassemble the output unit and check the inside and outside surfaces of the piston ring and cylinder	Replace the defective parts
Staples clog within the ejecting gate	Staples are inaccurately fed into the blade guide Incorrect Staples are loaded	Refer to first item	Refer to first item Use designated staples
	Worn tip of the driver blade	Carry out idle driving and check if blade tip if worn or not	Replace
	Worn guide groove of the blade guide	Check the wear of the blade guide	Replace
	Work piece material is too hard		Stop using the tool



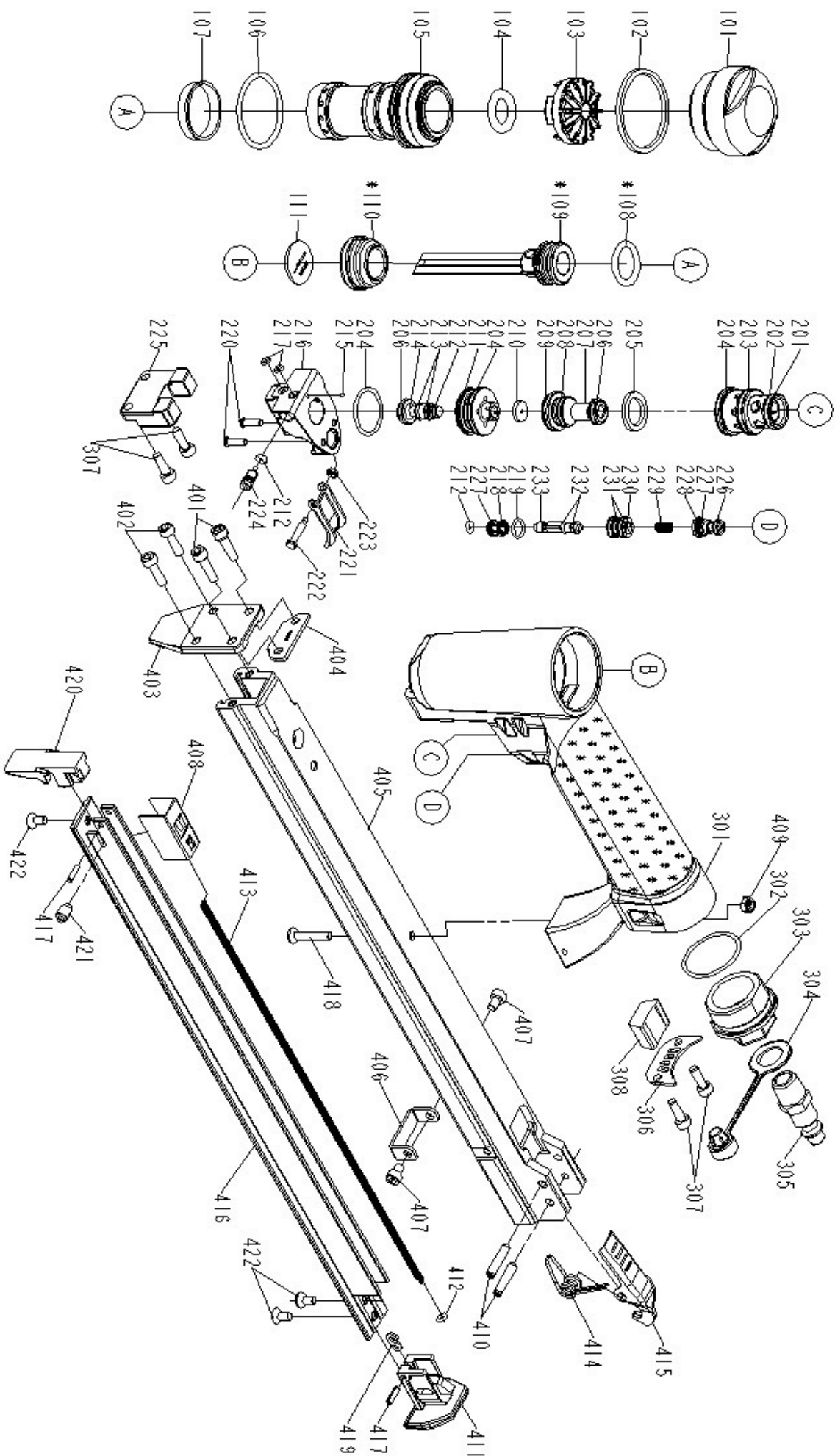

ITEM	PARTS NO	PARTS NAME	QTY	ITEM	PARTS NO	PARTS NAME	QTY
101	11371-0034704-1	DEFLECTOR	1	227	2041109-01060-0	O - RING	2
102	1132M-0034701-1	PACKING	1	228	11373-0030005-1	TRIGGER VALVE HEAD C	1
103	11370-0034702-2	SEAL	1	229	1133U-0014701-1	SPRING	1
104	2041107-02011-0	O-RING	1	230	11373-0030003-1	TRIGGER VALVE HEAD	1
105	11320-0030005-2	CYLINDER	1	231	2041109-01020-0	O - RING	2
106	2041109-04070-0	O - RING	1	232	2041104-01070-0	O - RING	2
107	11322-0034701-1	CYLINDER RING	1	233	11375-0034702-1	TRIGGER VALVE STEM A	1
108*	2041106-02010-0	O - RING	1	301	11230-003E801-1	GUN BODY UNIT	1
109	11204-0044705-1	DRIVER UNIT	1	302	2041109-03040-0	O - RING	1
110*	11327-0734701-2	BUMPER	1	303	11346-0031304-1	END CAP	1
111	11388-0044706-1	DRIVER GUIDE	1	304	1132L-0010001-1	AIR PLUG CAP	1
201	2041109-02120-0	O - RING	1	305	1135V-0000007-1	AIR PLUG	1
202	11373-0030004-2	TRIGGER VALVE HEAD B	1	306	11394-0034702-1	GUIDE PLATE	1
203	2041104-02080-0	O - RING	1	307	2040101-02060-0	HEX.SOC.HD.BOLT	4
204	2041109-03030-0	O - RING	3	308	1132T-0030002-1	MUFFLER	1
205	11399-0034701-1	COLLAR	1	401	2040100-02080-2	BOLT ASSY	2
206	2041108-01040-0	O - RING	2	402	2040101-02070-2	HEX.SOC.HD.BOLT	2
207	1133S-0030003-2	VALVE PLUNGER A	1	403	11351-0044712-2	DRIVER GUIDE COVER	1
208	2041104-02071-0	O - RING	1	404	11380-0044706-1	GASKET	1
209	2041104-02061-0	O - RING	1	405	11391-0044711-1	MAGAZINE B	1
210	1130J-0034702-1	CUSHION	1	406	1130S-0034702-1	STOPPER	1
211	11374-0030003-1	PLUNGER CAP	1	407	2040101-02020-2	HEX.SOC.HD.BOLT	2
212	2041104-01020-0	O - RING	3	408	11363-0044706-1	PUSHER	1
213	2041104-01080-0	O - RING	2	409	2040500-02010-0	LOCK NUT	1
214	1133S-0030004-1	VALVE PLUNGER B	1	410	2040401-07100-0	SPIRAL PINS	2
215	2040800-05010-0	BALL	1	411	11347-0044703-1	REAR PLATE	1
216	1133T-0034702-1	PLUNGER CAP	1	412	2041102-01030-0	O - RING	1
217	2041109-01080-0	O - RING	2	413	11328-0030002-1	PULL SPRING	1
218	11373-0030006-1	TRIGGER VALVE HEAD D	1	414	11315-0034703-1	SPRING	1
219	2041109-01030-0	O - RING	1	415	11343-0034705-1	LATCH	1
220	2040105-01020-0	ROUND CROSS SCREW	2	416	11389-0044710-1	MAGAZINE A	1
221	11316-0034703-1	TRIGGER	1	417	2040400-04050-0	SPRING PIN	2
222	11324-0684702-1	FIXED PIN	1	418	2040103-02100-5	COUNTER SUNK SCREW	1
223	1131D-0460001-1	URETHANE RETAINER	1	419	11323-0044704-1	POSITIONING SHEET	1
224	11393-0030001-1	ADJUST AXLE	1	420	11303-0044705-2	DRIVER GUIDE	1
225	1131F-0034702-1	ANCHOR BLOCK	1	421	11379-0040002-1	ROLLER	1
226	2041109-01150-0	O - RING	1	422	2040103-02050-3	COUNTER SUNK SCREW	3
					7USAX-3004001-1	O-RING KIT	1



Visit our web site  
**[www.axxisus.com](http://www.axxisus.com)**

Or

Email us @  
**[reception.inc@axxisus.com](mailto:reception.inc@axxisus.com)**

**COMPLETE**